

Irritrol® Get more done™

Rain Dial®

6-, 9- and 12-Station Irrigation System Controller



User's Guide

- **Setup**
- **Installation**
- **Programming**
- **Troubleshooting**

◆ Indoor and Outdoor Models RD-600 • RD-900 • RD-1200 ◆

❖ Table of Contents

Key Features	2–3
Getting Started	4
Battery Installation and Armchair Programming.	4-5
Overview: Control Module Interface.	6-7
Overview: Internal Controller Components	8-9
Installation Procedures	10–15
Installing the Controller Cabinet	10
Connecting the Valve Wires	10–11
Connecting the Earth Ground	12
Connecting the Power Source	13–15
Indoor Models	13
Outdoor Models	14–15
Station Test Run Feature	15
Getting the Most From Your Rain Dial Controller	16–17
Why Three Programs?	17
Sample Watering Plan.	17
What the Display Indicates	18–19
Basic Programming Procedures	20–23
Setting the Current Time and Day.	20
Setting the Valve Run Time.	20
Setting the Program Cycle Start Time(s)	20–21
Setting the Watering Day Schedule	21–23
To Set a Weekday Schedule:	21
To Set a Skip Days Schedule:	22
To Set an Odd/Even Date Schedule	22
Day Exclusion Feature	23

Special Functions and Features	24–29
Rain Delay Feature	24
Water Budget Feature	24
Stack/Overlap Control Feature	25
MV/Pump per Station Feature	26
Well Recovery Delay Feature	26
Pump Control During Well Recovery Feature	27
Diagnostic Circuit Breaker Feature	28
Clear Program Memory Feature	28
Factory Default Reset Feature	29
Manual Operations	30–31
Semi-Automatic Operation	30
Manual Station Operation	31
In Case of a Problem	32–34
Customer Support Information	32
Troubleshooting Information	32–33
Replacing the Fuse	34
Remote Control Feature	35
Specifications	36
FCC Rules	37
Product Inquiry Information	Back Page

❖ Key Features

Congratulations!

You have selected one of the most feature-packed yet simple-to-use sprinkler system controllers available.

To acquaint yourself with your new controller, take just a few minutes to review some key Rain Dial features, then follow the recommended procedures for installation, programming and operation.

- **Modular design** – Provides easy access to valve wiring terminals and battery. Simple, snap-out control module for convenient “Armchair” programming before installation.
- **Remote Control ready** – Built-in remote plug jack for use with Irritrol handheld remote models CMR-KIT and KSR-KIT.
- **Non-volatile Memory** – Keeps user-defined watering program information in memory for years—*without power!*
- **“Super Cap”** – Maintains current time and date up to 24 hours without A.C. power input or battery backup.
- **Battery back-up** – Maintains current time and date during an intermittent power outage. Also enables the Rain Dial to be programmed before prior to installation.
- **3 independent watering Programs** – Enables different watering routines to be set for trees, lawns and garden.
- **3 Start Times per Program** – Provides three separate watering cycle start times for each Program.
- **Skip Days scheduling** – Enables watering days to be determined by an interval ranging from 1 to every 31 days.
- **Odd/Even date scheduling** – Municipalities and water purveyors will sometimes mandate Odd/Even date watering as a water conservation measure. *No problem for Rain Dial!*
- **Day Exclusion with Odd/Even and Skip Days scheduling** – Enables individual days within an Odd/Even or Skip Days schedule to be excluded from operation.
- **Overlapping or Stacking of Programs** – Enables Programs or manual stations to operate one at a time or 3 simultaneously.
- **Station Test Program** – Enables a test run time to be set for all stations and operated in sequence. *Perfect for new installations!*

- **Live programming** – Enables programming changes to be made at any time—even during watering!
- **Fully automatic, semi-automatic and manual station operations.**
- **Manual Advance** – Enables quick manual advance up through the station sequence. Works in all Automatic, Semi-auto and Manual operations.
- **Off or Stop** – Immediately stops and prevents all watering activity without disturbing Programs.
- **Four places available to quickly remove start times** – Enables Start Times to be turned Off between 11:59 PM/12:00 AM, 11:59 AM/12:00 PM, 5:59 AM/ 6:00 AM and 5:59 PM/ 6:00 PM
- **Rain Delay** – Enables automatic watering to be postponed from 1 to 9 days, then automatically resume scheduled watering.
- **Water Budget** – Enables the run time of all stations within a Program to be scaled up or down from 0 to 200%.
- **MV/Pump On/Off per station** – Enables activation of the Master Valve/Pump circuit to be controlled by individual stations.
- **Timed delay between stations** – Enables a timed delay period to occur between stations in sequence to compensate for slow-closing valves and/or well recovery time.
- **Pump On/Off during timed delay** – For systems using a pressure pump, slow-closing valves would require the pump to be active during a delay between stations; a well-water recovery system may not—*Rain Dial provides the choice!*
- **Built-in circuit protection** – Helps protect Rain Dial's electronic components from damage due to power surges.
- **Diagnostic Circuit Breaker** – Enables the controller to detect and bypass any station with a short circuit or faulty solenoid. Displays "FUS" and the bypassed station number for easy troubleshooting.
- **Clear Program Memory** – Enables individual Program memory to be cleared without affecting other Programs.
- **Reset to Factory Program Defaults** – Enables factory default operating parameters to be easily restored if needed.

❖ Getting Started

Battery Installation & Armchair Programming

Installing the 9V battery serves two important purposes: first, to enable the Rain Dial to be fully programmed prior to installation, and second, to keep the control module synchronized with current time and date during a main power interruption lasting more than 24 hours.

The control module is designed to be easily removed for complete programming in a more convenient setting, such as your favorite armchair. To remove the control module, simply unplug the ribbon cable connector from the printed circuit board, then carefully remove the module from its snap-in hinges. The Rain Dial features non-volatile memory, which keeps the programming information intact, even if the battery dies or is disconnected.

Note: *The battery is not capable of operating the sprinkler valves. Main AC power must be applied to the controller to enable operation.*

Installing the Battery

1. Open the controller door.
2. Pull the control module open by grasping it from the right edge (press the module release tab on the outdoor model).
3. Locate the battery compartment at the top of the control module. Press down and outward on top of the cover to remove.
4. Attach the battery clip to the supplied 9V alkaline battery.
5. Store the battery in the compartment and reinstall the cover.
6. The display will begin flashing **12:00 AM** (press any button to halt).

Note: *To begin setting up a watering Program, refer to "Basic Programming Procedures" on page 20.*

⚠ CAUTION: To avoid hazards from improper battery type installation, always replace the battery with the same or equivalent battery type.

Always dispose of used batteries properly, as recommended by the battery manufacturer.

Figure 1

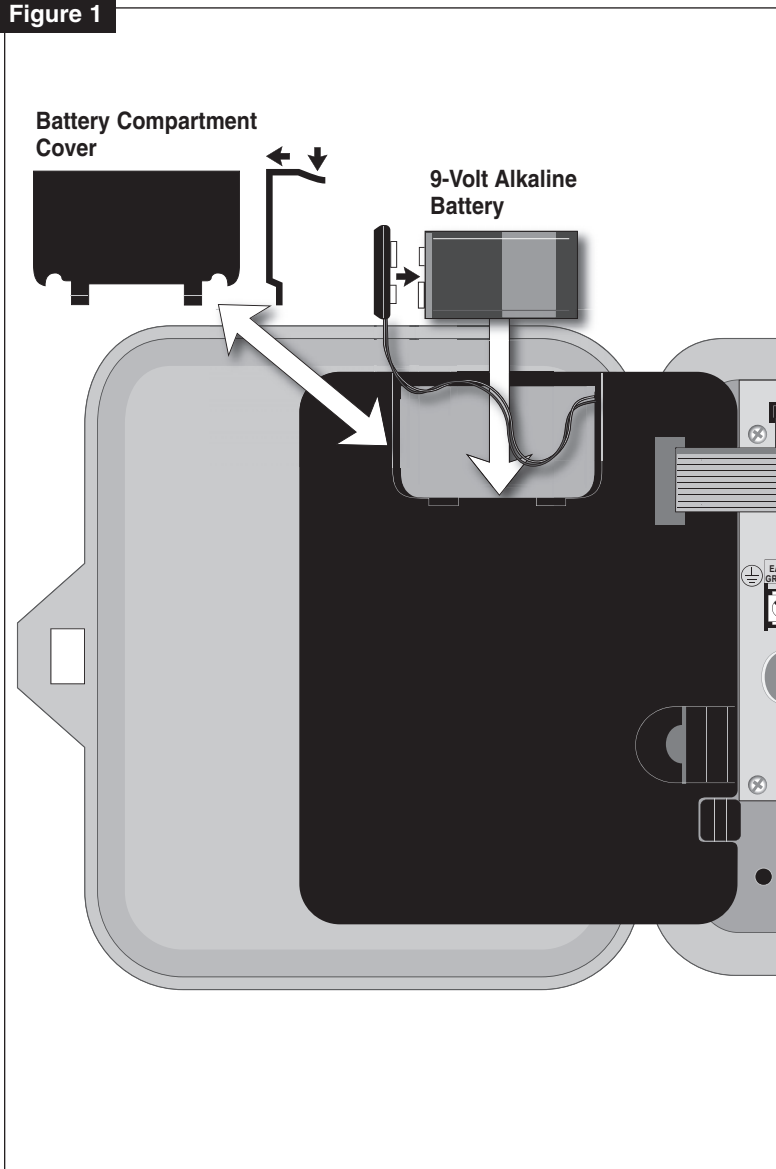

Overview: Control Module Interface

1 - Program Switch

- Three-position slide switch used to select Program **A**, **B** or **C** for setup, program review and manual operation.

2 - LCD Display

- High-contrast LCD panel displays all controller programming and operating information.

3 - Plus and Minus Buttons

- Push buttons used to increase and decrease display values during controller setup, programming and manual operations. Adjusts values incrementally (press and release) or by rapid scrolling (press and hold).

4 - Dial

- A 25-position rotary switch used to select stations, start times, watering days and special functions for setup, programming and manual operations.

5 - Manual Button

- Push button used to start and control manual operations by station. Also serves as an advance button for setup, programming and manual operations.

6 - Function Switch

- A three-position slide switch used to select one of three controller function modes:

Off or Stop - Stops all current watering operations, prevents all automatic and manual operations and used in setting Rain Delay feature.

Set Programs - Enables watering program setup values to be selected and changed.

Run or Manual - Normal switch position for all automatic and manual watering operations.

7 - Semi-Auto Start Button

- Push button used to manually start Program **A**, **B** or **C** watering cycle (as selected) or the Station Test Run feature.

Figure 2



Overview: Internal Controller Components

1 - Battery Compartment

- Snap-in cover provides easy access to 9V alkaline battery.

2 - Control Module Ribbon Cable

- Quick disconnect for easy removal of control module from cabinet to facilitate Armchair Programming or service.

3 - Ground Terminal (EARTH GROUND)

- Connection terminal for earth ground conductor wire.

4 - 2A Slow-blow Fuse

- Safety fuse provides current overload protection to the 24 VAC power source caused by a short-circuit condition.

5 - 24 VAC Terminals

- Connection terminals for plug-in transformer. Also provides power source for CMR-KIT handheld remote.

6 - Valve Common Terminal (VC)

- Connection terminal for the valve (field) common wire.

7 - Master Valve/Pump Terminal (MV/PUMP)

- Connection terminal for master valve or 24 VAC pump start relay.

8 - Numbered Valve Terminals

- Connection terminals for valve wires. One terminal provided per valve station (RD-1200 12-station model shown.)

9 - Remote Control Plug Receptacle

- Phone-style jack provided for connection of a CMR-KIT or KSR-KIT-K handheld remote adapter cable.
Refer to "Remote Control Feature" on page 35.

⚠ Caution: The Rain Dial is designed to operate 24 VAC valve solenoids rated at 0.25A (6 VA). Current total load must not exceed 1.0A maximum. A maximum of two solenoids per station terminal may be used, but not to exceed 0.5A per station. No more than three solenoids (plus MV/Pump circuit) should be on at any one time .

To prevent controller damage, do not link the valve common wire of two or more controllers. Use a separate valve common wire for each controller.

Figure 3

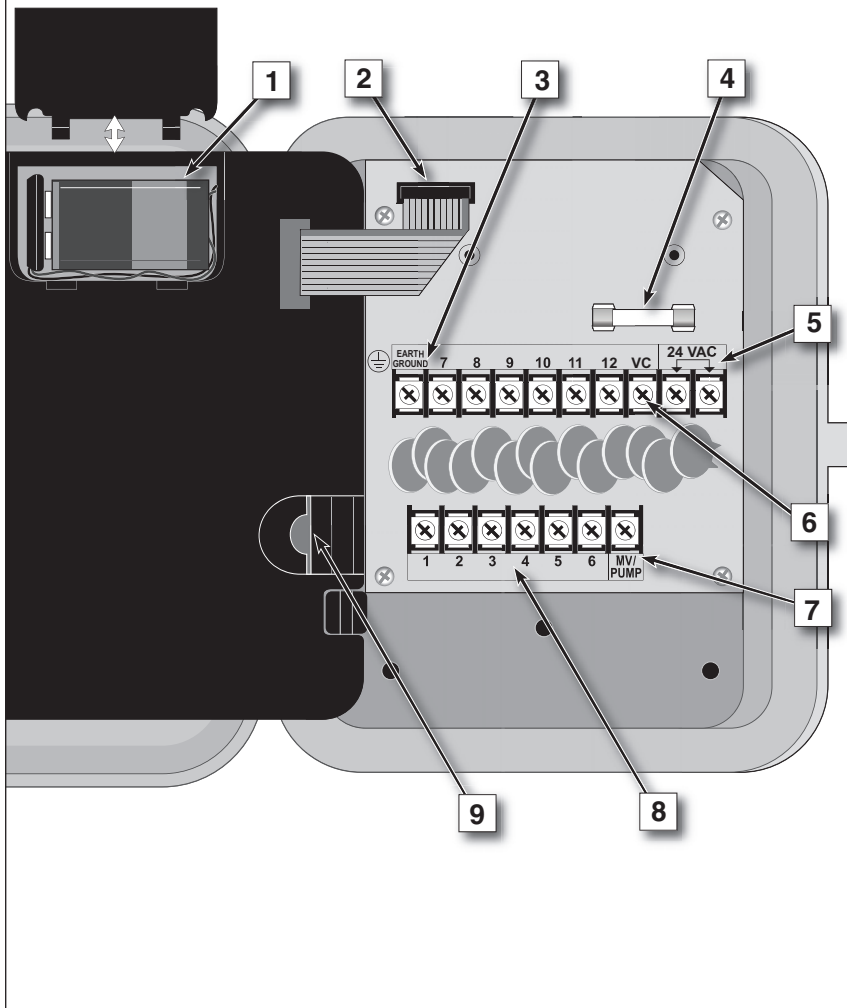

❖ Installation Procedures

Installing the Controller Cabinet

Locate the indoor model in a protected area, such as a garage, within 5' (1.5m) of a grounded electrical outlet. Locate the outdoor model avoiding direct exposure to sun and irrigation spray. Do not install the controller within 5' (1.5 m) of any motorized equipment.

1. Drive a #10 wood screw (provided) into a wall stud, at a convenient level, leaving about 1/4" (6.5 mm) of the screw exposed.

Note: Use screw anchors when installing on drywall or masonry.

2. Hang the controller on the screw using the keyhole slot provided.
3. To secure the controller, drive one or two screws through the lower mounting holes provided.

Note: The Outdoor cabinet lower mounting holes have a thin flashing that is easily penetrated when installing the mounting screws.

Connecting the Valve Wires

Note: Using 14–18 gauge irrigation valve connection cable is recommended. Always use a cable that has at least one wire for each valve and one wire for the valve common connection. Secure all wire splices using water-proof wire connectors.

1. Route the wire cable from the controller to the valve location.
2. To provide a Valve Common wire, attach either lead of each valve solenoid to one cable wire. *The white wire is generally used for this connection.*
3. Attach a separate cable wire to the remaining lead from each valve solenoid. *Note the wire color used for each connection to reference at the controller.*
4. Route the cable into the controller through the large opening in the base of the cabinet.

Note: The outdoor cabinet has a threaded opening for optional 1.25" conduit installation. Install conduit at this time as necessary.

5. Cut the cable back as necessary, then strip 1/2" (13 mm) of insulation from the end of each wire. Using a small screwdriver, connect each valve wire to a numbered valve terminal, referring to the wire color code used for each valve connection.

6. Connect the Valve Common wire to the terminal labeled “VC.”
7. Connect the master valve or pump start relay control wire (if applicable) to the terminal labeled “MV/PUMP.”

Note: The controller does not supply power to operate the pump. The pump start relay or master valve must have a nominal coil voltage of 24 VAC at 0.375A.

Figure 4

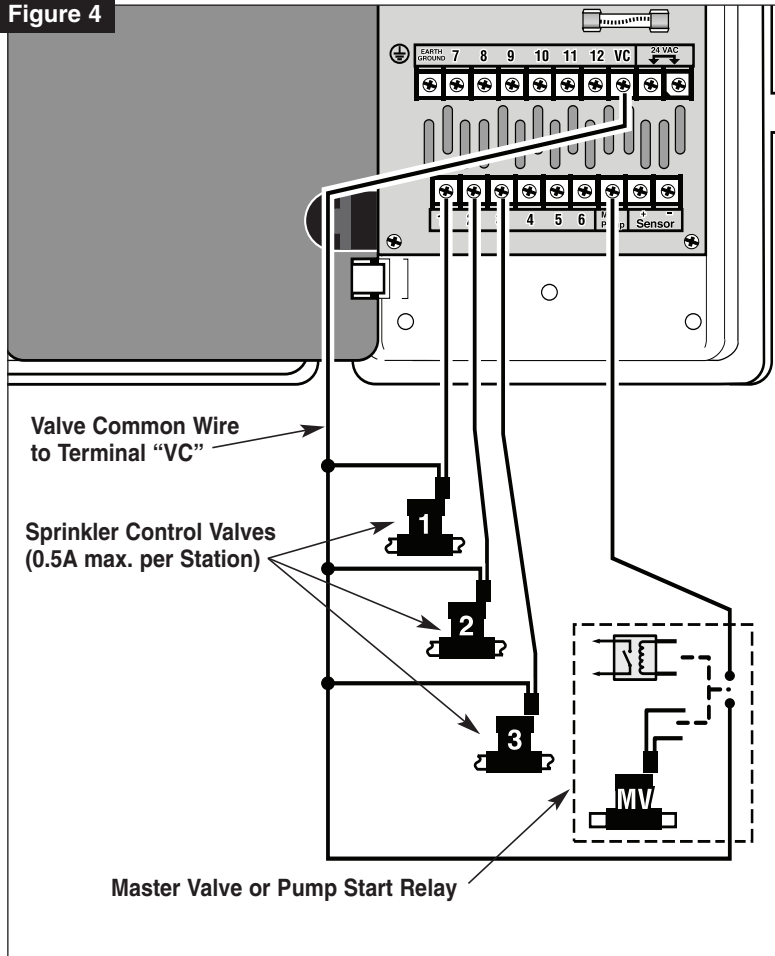

Connecting the Earth Ground

Note: The built-in circuit protection in all Rain Dial controllers requires an earth ground path, such as a copper-clad ground rod or metal water pipe, to help protect the controller from power surges, and is especially important in lightning-prone areas.

1. Connect a 12–16 gauge solid-copper wire to the ground device and route into the controller cabinet through the field wire opening.
2. Secure the ground wire to the terminal labeled “Earth Ground.”

Figure 5

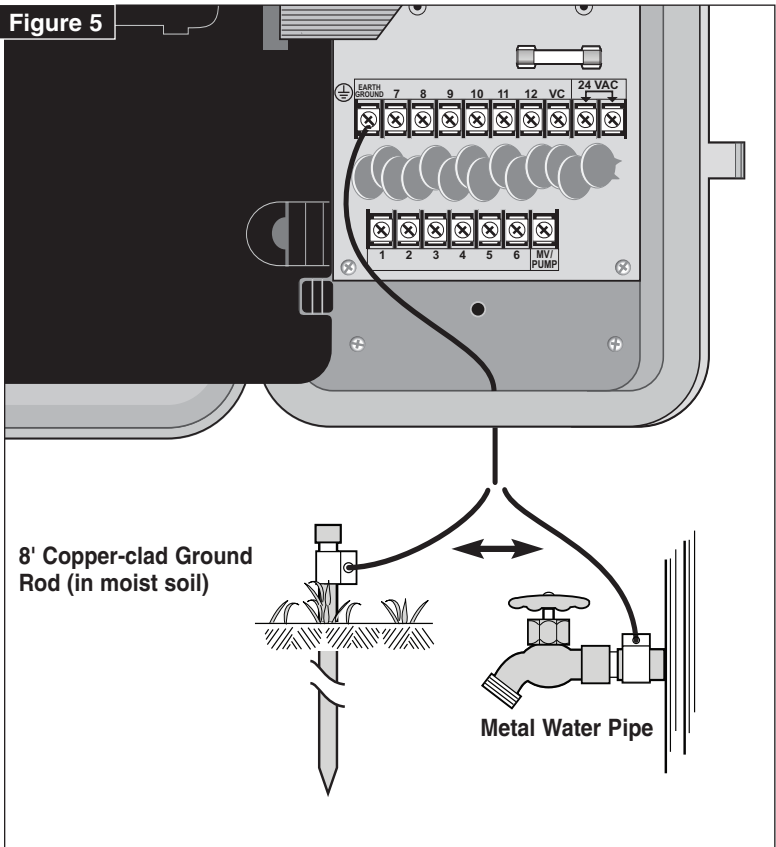

Connecting the Power Source

Indoor Models

1. Route the plug-in transformer cable through the small hole provided in the bottom of the cabinet.
2. Tie a knot in the cable to provide a strain relief, and connect the wires to the terminals labeled “24 VAC” (in either order).
3. Close the control module and plug the transformer into a wall outlet. The controller is now ready to program and operate.

Note: To immediately test-run the Rain Dial irrigation control system, refer to the “Station Test Run Feature” on page 15.

Figure 6

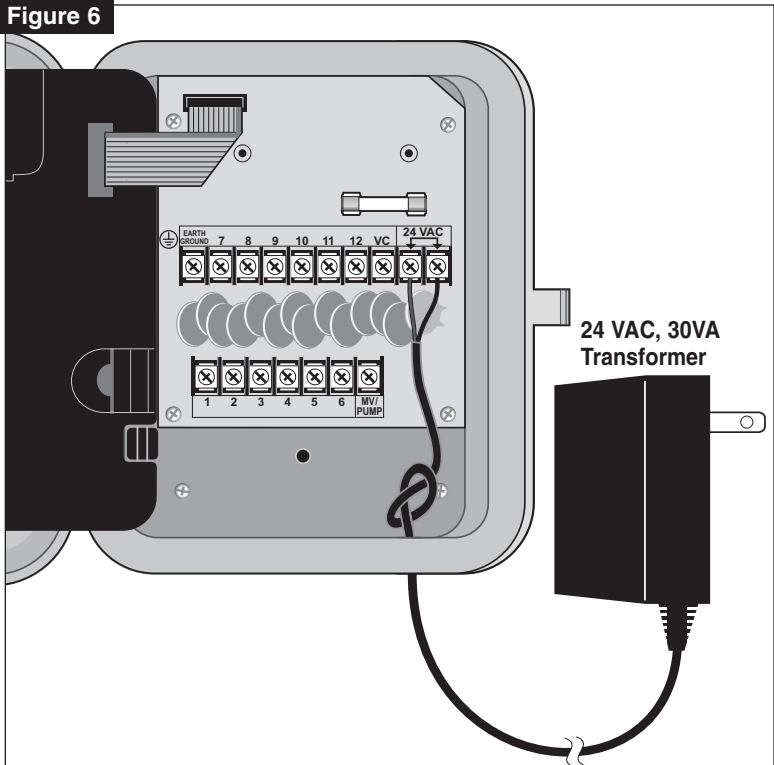

Connecting the Power Source

Outdoor Model

⚠ WARNING: All electrical components must meet applicable national and local electrical codes including installation by qualified personnel. These codes may require a junction box installed on controller's 1/2" NPT nipple and a means in the fixed wiring of disconnecting AC power having a contact separation of at least 0.120" (3mm) in the line and neutral poles. The connection wire must have insulation rated @ 105° C min. Verify that power has been turned off at the power source by using an AC volt meter prior to connecting controller wiring.

⚠ Caution: The controller must be connected to a grounded power source. Do not connect to one phase of a 3-phase power supply used by a pump or other electrical equipment.

Note: Electrical conduit and adapters are not supplied with the controller but are generally required by electrical codes. Check local codes and install accordingly.

Note: Australian controller models are equipped with a plug-in power cord. For power connection, insert the plug into a grounded 240 VAC, 50 Hz outlet.

1. Install a 1/2" (13 mm) NPT threaded conduit body to the transformer assembly nipple. From the conduit body, install electrical conduit to the AC power source as required.
2. Route the Hot, Neutral and Equipment Ground wires through the conduit into the conduit body.
3. Using the proper size wire connectors, splice the mating wires as shown in **Figure 7**.
4. Close and secure the conduit body cover.
5. Apply power to the controller and check controller operation. If the controller is not operating, disconnect the power at the source and have a qualified electrician check for possible short circuit.



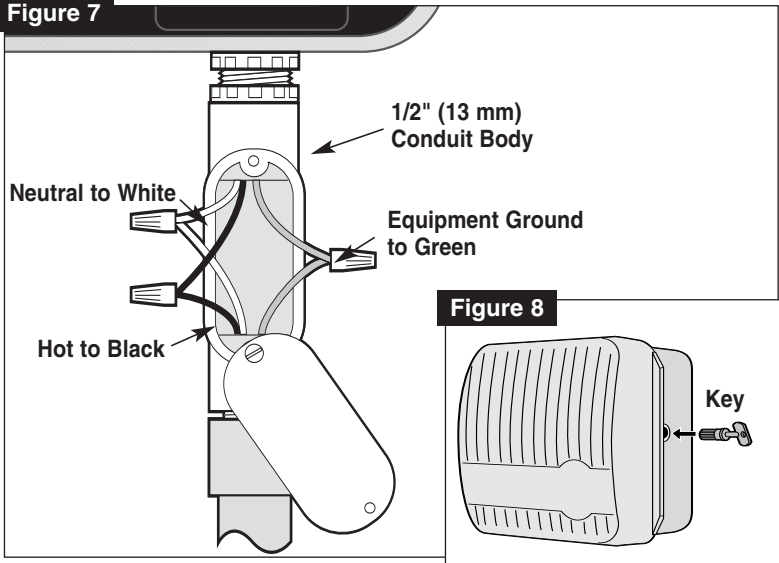

⚠ CAUTION: Keep the outdoor cabinet closed and locked when possible to protect electronic components. Store keys (2) in a safe location. See **Figure 8**.

Figure 7



Station Test Run Feature

The **Station Test Run** feature enables all stations to be automatically operated in sequence using a temporary run time from 1 to 10 minutes. Perfect for a quick check of the system after installation or service.

1. Place the **Function** switch in the **Run** position.
2. Turn the **Dial** to the **Skip Days/Special Functions** position.
4. Press the **Manual**  button one time to move from the initial **Skip Day** screen to the **Station Test** screen.
3. Use the  and  buttons to set the desired run time.
5. Press the **Semi-Auto**  button to start the watering cycle.
6. Turn the **Dial** to the **Current Time** position.

Note: Once started, the station sequence can be manually advanced by pressing the **Manual**  button.

❖ Getting the Most from Your Rain Dial Controller

- **The basic watering cycle** – Once a program is given a start time, it causes each station with an assigned run time in the program to operate in sequence, beginning with the lowest numbered station. When all stations have run in sequence, the watering cycle is over.
- **Avoid unexpected start times** – It is possible to set a second start time that begins before the cycle from the first start time has finished. When this happens, the start of the second cycle is delayed until the first is complete; so the start time may not occur when you expect it. In addition, increasing run time in the water budget feature may cause an overlap that delays successive start times.
- **Avoid watering on a non-watering day** – If you use Odd/Even date scheduling, be careful when planning start times to allow enough time to run the entire cycle before midnight.
- **Avoid excessive watering** – All three programs (**A**, **B**, and **C**) are always on. Start times entered for any program will begin automatically when that time occurs. Multiple programs are meant to water different zones or to supplement watering if one program is not enough. If you need extra water, use more than one start time and/or use the Water Budget feature.
- **Avoid Creating a low water pressure condition** – Start times assigned to different programs are independent. If you set identical or overlapping start times, all can turn on at the same time. The maximum flow might exceed the water supply available. To avoid this situation, allow more time between start times to reduce the number of valves running at one time. Also, make sure that different programs have different start times.
- **Establishing new lawns** – Having short, multiple watering cycles each day is especially useful when establishing a new lawn.
- **Help with electrical problems** – The Rain Dial will display a station number and the word “**FUS**” if a short circuit on a valve control circuit is detected. The station will be skipped, allowing the remaining stations to run in the Program watering cycle.

Why three watering programs? – Different plant types requires varying amounts of water. Rain Dial allows you to segregate different plant types and assign watering in three different programs (**A, B & C**).

The following example below shows how this can be accomplished:

Sample Watering Plan

Program	Start Time	Valve #	Location	Run Time	Schedule
A	(#1) 5:00 AM	1	Front Lawn	15 min.	Odd
		2	Back yard	15 min.	Odd
		3	Side Yard	10 min.	Odd
B	(#1) 3:00 PM	4	Trees drip	2 hrs.	Mon
C	(#1) 4:00 AM	5	Garden	5 min.	Skip Days, 1
		(#2) 7:30 PM	5	Garden	5 min.

Figure 9

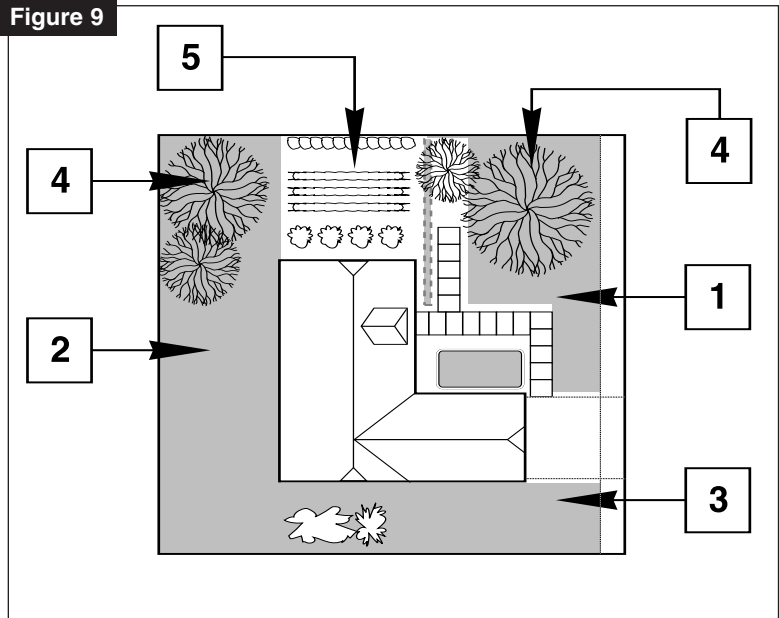

What the Display Indicates

Information Displayed When Programming

The **Display** will show the following information with the **Function** switch in the **Set Programs** position, in conjunction with the following **Dial** settings:

Valve Run Time - Shows run time in minutes or hours. Also displays **OFF** for unused valves.

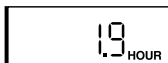

Start Times - Displays Program time or **OFF** for unused start times.

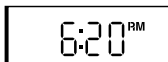

Skip Days - Shows days numbered 1–31, or **OFF** and **Once Every** will be displayed.

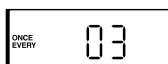

Schedule - Displays **ON** or **OFF**. If **Skip Days** has been set, three dashes (- - -) **Skip Mode** will be displayed.

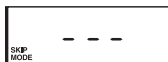

Odd/Even Date - Shows **Odd** or **Evn** (Even) watering day schedule if selected (or **OFF** if excluded).



Today - Displays seven individual days for a weekly schedule, or displays the day in the Skip Day interval 1–31 for a **Skip Days** schedule.



Pump Circuit On/Off during station operation- Indicates if the pump circuit will be On or Off when the station runs.

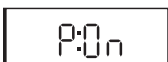

• Special Functions Dial Setting:

Test Run Cycle - All station numbers with an assigned run time will be shown. **T:1–10** minutes will indicate the station run time selected for test cycle.

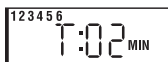

Water Budget - Shows current Water Budget setting of 0 –100 (%) or **OFF**.



Clear Program Memory - Indicates clear memory function is selected.



Well Recovery Delay - Shows amount of delay time set between stations: 1 second to 2 hours (or **OFF**).

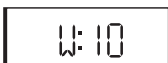

Pump circuit On/Off during well recovery -

Indicates if pump circuit will be On or Off during a well recovery period.



Program Stacking/Overlap - If program stacking is selected, **1:on** will be displayed. If program overlap is selected, **3:on** will be displayed.

**Information Displayed During Operation** 

With the **Function Switch** in the **RUN** position and the dial set to **Current Time**, the currently operating valve number will be displayed.



Automatic Mode with No Program ON - With the **Function Switch** in the **RUN** position, the current time with a flashing colon (:) is displayed. If the colon is not flashing, the controller is using battery power.

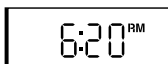

Automatic or Semi-Auto Mode With Program ON - Displays the current time. Turn the dial to an active valve and the display will show the valve number, the program (**A**, **B** or **C**) and the time remaining for that valve to run.

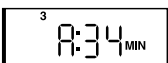

Manual Mode - With the **Dial** pointing to the appropriate valve number, the display shows the valve's number, an **M** (for manual), and the time remaining for the valve to run.

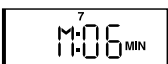

Diagnostic Circuit Breaker - The message FUS and the effected station number will be displayed alternating with the current time of day.



Rain Delay - When the Rain Delay feature is in use, the display will alternate between the current time of day and the number of days remaining until automatic watering resumes. This example indicates 9 delay days remaining.

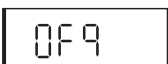

❖ Basic Programming Procedures

Setting the Current Time and Day

1. Place the **Mode Switch** in the **Set Programs** (center) position.
2. Turn the **Dial** to the **Current Time** position.
3. Use the **+** and **-** buttons to set the current time (note the correct AM/PM designation). *Hold the button down to scroll.*
4. Turn the **Dial** to the **Today** position.
5. Use the **+** and **-** buttons to set the current day (abbreviation).
6. Turn the **Dial** to the **Current Time** position when finished.



Setting the Valve Run Time

Each station can have a different run time assignment in each program (**A**, **B** and **C**). The run time can be set from 1 to 59 minutes in one-minute increments or from 1 to 5.9 hours in $\frac{1}{10}$ -hour increments.

1. Place the **Function** switch in the **Set Programs** (center) position.
2. Place the **Program** switch to select **A**, **B** or **C**.
3. Turn the **Dial** to the **Valve Run Time** number to be set.
4. Use the **+** and **-** buttons to set the run time. *Hold the button down to scroll. The display will continuously scroll from minutes to hours.*
5. Repeat steps 2 and 3 for the remaining valves you wish to set
6. Turn the **Dial** to the **Current Time** position when finished.

Setting the Program Cycle Start Time(s)

Each Program can have up to three separate watering cycle start times. Generally one start time is sufficient for most applications. Multiple start times and short run times work well for growing-in a new lawn or establishing fresh sod.



1. Place the **Function** switch in the **Set Programs** position.
2. Place the **Program** switch to select **A**, **B** or **C**.
3. Turn the **Dial** to the **Start Time 1** position.
4. Use the  and  buttons to set the start time.
Hold the button down to scroll. The display will continuously scroll through the minutes and hours.
Note: To turn a Start Time **OFF**, select one increment past 11:59 or 5:59 (AM or PM).
5. Repeat steps 3 and 4 for the remaining program cycle start times you wish to set.
6. Turn the **Dial** to the **Current Time** position when finished.

Setting the Watering Day Schedule

Three types of watering schedules are available for each Program:

- **Weekdays** - Enables individual days of the week to be set to water.
- **Skip Days** - Sets watering days by frequency. For example, every day (01), every-other-day (02) etc.
- **Odd/Even Date** - Sets watering days by Odd or Even calendar day number.

To Set a Weekday Schedule:

1. Place the **Function** switch in the **Set Programs** position.
2. Place the **Program** switch to select **A**, **B** or **C**.
3. Turn the **Dial** to select the **Schedule (Sun–Sat)** weekday position you wish to set.
4. Use the  and  buttons to select **ON** or **OFF**.
5. Repeat steps 3 and 4 for the remaining days you wish to set for the selected program.
6. Turn the **Dial** to the **Current Time** position when finished.

To Set a Skip Days Schedule:

Note: To set a **Skip Days** schedule, **Odd/Even** mode must be **OFF**.

1. Place the **Function** switch in the **Set Programs** position.
2. Place the **Program** switch to select **A**, **B** or **C**.
3. Turn the **Dial** to the **Skip Days/Special Functions** position.
4. Use the **+** and **-** buttons to select **Once Every 01–31** to set the **Skip Day** interval.







Note: Once a **Skip Days** interval is selected, **OFF** will be replaced with “**Once Every**” and the **Skip Days** number you select.

5. Turn the **Dial** to the **Today** position.
6. Use the **+** and **-** buttons to select the current day in the interval.
For example, watering is set to occur every-four-days (on day 4), and you want the next watering day to be in three days, select 01; in two days, select 02; tomorrow, select 03 or today, select 04.
7. Turn the **Dial** to the **Current Time** position when finished.

To Set an Odd/Even Date Schedule:

Note: To set an **Odd/Even** schedule, **Skip Days** mode must be **OFF**.

1. Place the **Function** switch in the **Set Programs** position.
2. Place the **Program** switch to select **A**, **B** or **C**.
3. Turn the **Dial** to the **Skip Days/Special Functions** position.
4. Press the **Manual** **ON** button repeatedly (seven times from the initial **Skip Day** screen) to display dashes (---).
5. Press the **+** button to select **Odd**, or press the **-** button to select **Even (EVn)**. *To turn the Odd/Even schedule Off, press either button until (---) is displayed.*
6. Press the **Manual** **ON** button once to select the calendar **Month** setting. January (JA) will be displayed.
7. Press the **+** or **-** button to select the current month abbreviation:
JA = January, Fe = February, MR = March, AP = April, My = May,
JN = June, JL = July, AU = August, SE = September,
OC = October, nO = November and DE = December.

8. Press the **Manual**  button one time to select the **Day** setting.
9. Use the  and  buttons to select the current calendar day.
*For example, April 4 would be displayed as **A:04**.*
10. Press the **Manual**  button one time to select the **Year** setting.
11. Use the  and  buttons to select the year (2007 = 07).
12. Turn the **Dial** to the **Current Time** position when finished.
13. Place the **Function** switch in the **Run** position.

Note: When using the Odd/Even Date mode, the day of the week (at the “Today” position) cannot be changed from the calendar day.



Note: Odd/Even watering never occurs on day 31 of any month or February 29th of a leap year.

Note: This completes the basic steps required to set up an automatic irrigation Program. To set up additional programs, simply repeat the step-by-step process, starting at “**Setting the Valve Run Time.**”

Note: For advanced control of pump or master valve operation, refer to pages 26 and 27 to review and apply the optional control features.

Day Exclusion Feature

The **Day Exclusion** feature enables specific weekdays to be excluded from a **Skip Days** or **Odd/Even** watering schedule. Since both of these scheduling methods result in random watering day patterns, preventing watering on or before scheduled mowing/maintenance days is often required and easily accomplished.

1. Place the **Function** switch in the **Set Programs** position.
2. Place the **Program** switch to select **A**, **B** or **C**.
3. Turn the **Dial** to the **Schedule Day** to be excluded.
4. Press the  or  button display **OFF**.
5. Repeat steps 3 and 4 to exclude additional days.
6. Turn the **Dial** to the **Current Time** position.
7. Place the **Function** switch in the **Run** position.

❖ Special Functions and Features

Rain Delay Feature

The **Rain Delay** enables the Rain Dial to suspend all automatic watering activity from 1 to 9 days.



1. Place the **Function** switch in the **OFF** position.
2. Press the  button to set 1 to 9 delay days (**OF 1 – OF 9**).
3. Place the **Function** switch in the **Run** position.

The display will begin alternating between the current time and the number of delay days remaining. The delay day number will decrease each day until watering automatically resumes at the end of the selected delay period.

Note: To disable Rain Delay at any time; returning the controller to active mode, repeat steps 1 and 2 to decrease the Rain Delay day to one increment below **OF 1** (current time will be displayed).

Water Budget Feature

The **Water Budget** feature enables the run time of all stations assigned to a Program to simultaneously adjusted up or down by percentage from 0 (**OFF**)–200% in 10% increments.

1. Place the **Function** switch in the **Set Programs** position.
2. Place the **Program** switch to select **A**, **B** or **C**.
3. Turn the **Dial** to the **Skip Days/Special Functions** position.
4. Press the **Manual**  button two times (from the initial **Skip Day** screen) to display **100**.
5. Use the  and  buttons to set the desired percentage.

Note: To turn the Program Off, press the  button to display **OFF** (one increment below 10).



6. Turn the **Dial** to the **Current Time** position.
7. Place the **Function** switch in the **Run** position.

Stack/Overlap Control Feature

The **Stack/Overlap Control** feature provides the option to restrict operation to one Program or station at a time (stacked) or to enable three Programs or three stations to operate concurrently (overlap).

Note: *The Stack option prevents another Program or station from starting until the one in operation is finished. If a Program's start time is delayed past midnight it will not run.*



IMPORTANT: *Selecting the Overlap option can cause the electrical and/or hydraulic capacity of your irrigation system to be exceeded. Plan your watering operations carefully!*

1. Place the **Function** switch in the **Set Programs** position.
2. Turn the **Dial** to the **Skip Days/Special Functions** position.
3. Press the **Manual**  button 6 times (from the initial **Skip Days** screen) to display **3:On** (three programs/stations overlap).
4. Press the  or  button to toggle between **3:On** and **1:On** (stack - one program/station at a time).
5. Turn the **Dial** to the **Current Time** position.
6. Place the **Function** switch in the **Run** position.

MV/Pump Control per Station Feature



This feature enables the MV/Pump circuit to be automatically turned On and Off by specific station as needed, where only certain stations require a booster pump to increase system pressure. The default setting is pump On (P:ON) for all stations.

Note: *Applies to the station regardless of it's Program assignment.*

1. Place the **Function** switch in the **Set Programs** position.
2. Turn the **Dial** to the desired station number (station run time will be displayed).
3. Press the **Manual**  button: **P:ON** (Pump On) will be displayed.
4. Press  button to select **P:OF** (Pump Off). Press the  button to reselect **P:On**.
5. Turn the **Dial** to the **Current Time** position.
6. Place the **Function** switch in the **Run** position.

Well Recovery Delay Feature

The **Well Recovery Delay** feature enables an adjustable delay period, ranging from 1 second to 2 hours, to be entered between consecutive stations during a watering cycle to compensate for well/cistern recovery time or slow-closing valves.



1. Place the **Function** switch in the **Set Programs** position.
2. Place the **Program** switch to select **A**, **B** or **C**.
3. Turn the **Dial** to the **Skip Days/Special Functions** position.
4. Press the **Manual**  button 4 times (from the initial **Skip Days** screen) to display **W:00** (no delay).
5. Use the  and  buttons to set the desired time: 0–59 seconds, 1–59 minutes or 1.0–2.0 hours.

Note: *Hold the button down to scroll. The display will continuously scroll from seconds to minutes to hours (:00 = no delay).*

6. Turn the **Dial** to the **Current Time** position.
7. Place the **Function** switch in the **Run** position.

Pump Control During Well Recovery

The **Pump Circuit Control** feature enables the pump or master valve to be automatically turned On or Off in conjunction with the **Well Recovery Delay** feature. The pump/master valve circuit is energized at the beginning of the watering operation and remains on for the duration of the cycle. In some systems, the pump is not pressure limited and will continue to operate during a delay in the watering cycle, causing a pump “Dead Head” or over-pressure condition. Similar to all other Special Functions, this feature is Program-specific; applying only to the selected Program.

1. Place the **Function** switch in the **Set Programs** position.
2. Place the **Program** switch to select **A**, **B** or **C**.
3. Turn the **Dial** to the **Skip Days/Special Functions** position.
4. Press the **Manual**  button 5 times (from the initial **Skip Days** screen) to display **P:0F** (Pump Off).
5. Press the  or  button to toggle between **P:0F** and **P:On** (Pump On).
6. Turn the **Dial** to the **Current Time** position.
7. Place the **Function** switch in the **Run** position.

Diagnostic Circuit Breaker Feature

The message “**FUS**” and the malfunctioning station number will be displayed if a short circuit is detected. The station will be bypassed during the watering cycle enabling the remaining stations in the watering cycles to run. The **FUS** display will alternate with the current time display.

IMPORTANT: Determine the cause of the problem and take corrective action as necessary.



With the **Dial** set in the **Current Time** position, press any button to clear the “**FUS**” display.

Clear Program Memory Feature

The **Clear Program** memory feature enables any Program to be quickly erased when removal or reprogramming is desired. The memory erase function applies only to the specified Program; leaving all remaining Program setup information intact.

IMPORTANT: The Clear Program process completely erases all operating information from the selected Program (no start times, run times or active days).

Note: To return the Program back to factory default settings, refer “Factory Default Reset Feature” on page 29.

1. Place the **Function** switch in the **Set Programs** position.
2. Place the **Program** switch to select **A**, **B** or **C**.
3. Turn the **Dial** to the **Skip Days/Special Functions** position.
4. Press the **Manual**  button three times (from the initial **Skip Days** screen) to display **CLr** (Clear).
5. Press the  button one time. The display will show the prompt: **CL?** (Clear?).
6. To complete the clearing process, press the  button again. The display will show **End** to signify program memory is cleared.

Factory Default Reset Feature

The Rain Dial factory default Program settings are as follows:

Current Time: 12:00 AM.

Current Day: Sunday.

Current Date: January 1, 2006.

Program **A**: Weekday watering schedule with all days active.

One start time at 7:00 AM.

All stations have 10-minute run time.

Program **B** and **C**: No watering days, station run times or start times.

Skip Days and Odd/Even day schedule: OFF - all Programs.

Excluded days in Skip Days or Odd/Even schedule: None.

MV/Pump operation: ON - all stations.

Well Recovery period: 00 (OFF) - all Programs.

MV/Pump operation during Well Recovery: OFF - all Programs.

Water Budget: 100% - all Programs.

Rain Delay: 0 days.

Stack/Overlap: Overlap - 3 Programs or manual stations.

To restore factory default settings:

1. Place the **Function** switch in the **Set Programs** position.
2. Place the **Program** switch to select **B**.
3. With AC power connected, carefully disconnect the control module ribbon cable from the PC Board socket.
4. Open the battery compartment and disconnect the battery.
5. Press and hold the **Manual**  button in.
6. Reconnect the ribbon cable, then release the **Manual** button.
***Note:** The display should now show 12:00 AM. If it does not, repeat the procedure as necessary.*
7. Reinstall the battery.
8. Reprogram the controller.

❖ Manual Operations

Semi-Automatic Operation

Semi-Automatic operation enables a selected Program watering cycle to be started manually. Once running, the manual advance feature enables you to step through the programmed station sequence.

1. Place the **Function** switch in the **Run** position.
2. Turn the **Dial** to the **Current Time** position.
3. Place the **Program** switch to select **A**, **B** or **C**.
4. Press the **Semi-Auto**  button to start the watering cycle.

Note: Once started, the station sequence can be manually advanced by pressing the **Manual**  button.

Note: The Manual Advance feature applies to all Automatic, Semi-Automatic and Station Test watering operations for the selected Program.

Note: To terminate watering operations, place the Function switch momentarily in the **OFF** position.

Manual Station Operation

Manual Station operation provides manual control at the individual station level and provides the following four control options:

- Station(s) can be operated for a one-time run duration without altering the station's set run time in an automatic Program.
- Operation can be limited to only one station running manually or set to allow three stations to run at the same time.

Note: Refer to "Program Stack/Overlap Control" on page 25 for additional information on this feature.

- All stations can be set (stacked) for manual operation, with either one or three stations running at a time.
- Works with the Manual Advance feature to move up through the station sequence.

1. Place the **Function** switch in the **Run** position.
2. Turn the **Dial** to the **Station Number** to be manually operated.
3. Use the **+** and **-** buttons to set a manual operation run time ranging from 1 minute to 5.9 hours.
4. Press the **Manual** **ON** button to start the operation.
5. If this is the only station to be run manually, skip step 6 and continue at step 7 below.
6. To add additional stations to the manual run operation, repeat steps 2 through 4 as needed, then continue at step 7.

Note: Depending upon the Stack/Overlap setting, additional stations selected (beyond the one or three option setting) will register as OFF when entered with the Manual button. However, they will be placed (stacked) in the manual sequence to run.

7. Turn the **Dial** to the **Current Time** position.

Note: Once started, the station sequence can be manually advanced by pressing the **Manual** **ON** button.

Note: To terminate manual watering operations, place the **Function** switch momentarily in the **OFF** position.

❖ In Case of a Problem...

If a problem arises with your new Rain Dial controller that cannot be resolved with the following troubleshooting solutions, give us a call and we will be glad to help. Our Customer Support Team is available to answer any question or concern you may have regarding your Rain Dial controller or any Irritrol product.

Call us toll-free at 1-800-634-TURF (8873), Monday through Friday, 7:30 AM to 4:00 PM (Pacific).

Also, see us online at: www.irritrol.com for complete information on the entire **Irritrol** product line.

Troubleshooting

Problem	Possible Cause	Correction
Some valves do not operate.	Defective solenoid and/or loose wire connection.	Test and replace solenoid. Secure wire connections. Check for connection continuity.
No valves operate.	Function Switch in OFF position. Deflective valve solenoid. Loose wire connection. Day set to OFF . Skip Days incorrectly set. Start Times set to OFF .	Set switch to Run or Manual position. Test and replace valve solenoid. Secure wire connections (especially the common wire or “VC” connection). Check current day in display. Set Dial to the correct day and check setting. Check and reprogram Skip Days schedule option. Reset Start Times . Turn off Rain Delay .

Problem	Possible Cause	Correction
Watering at wrong times.	Current Time of day incorrectly set.	Reset to current time (correct AM or PM).
Blank display	No power.	Check circuit breaker panel, wiring connections, transformer and 2A fuse.
Program won't display.	Wrong Function switch setting. Controller is currently in a watering cycle.	Place Function switch in the Run position. Check or change program with Function switch in Set Programs .
Incorrect display (after a power outage or being unplugged).	Battery is weak, dead or not installed.	Remove AC power and battery for one minute. Install/replace battery and restore power.
Watering on wrong day.	Watering day schedule not set correctly.	Reset Program watering day schedule (p.22).
Current time is wrong and flashing.	Power outage occurred without battery backup.	Install/replace battery and reset time.
Display is flashing. "FUS" and station number are shown.	Excessive current load due to shorted wire or defective solenoid.	Check wiring and splices for short circuit. Replace defective solenoid.
Valve will not turn off (with Function switch in the OFF position).	Valve malfunction or manual On (bleed) mechanism open.	Carefully turn solenoid or manual bleed screw if present, clockwise to close and shut off valve. Repair/replace valve as necessary.

❖ Replacing the Fuse

The Rain Dial utilizes a 2.0A Slow-blow fuse to protect the controller on the 24 VAC input power. If the fuse blows, check for the probable cause of the condition and take corrective action before replacing the fuse.



WARNING: The 2.0A safety fuse protects the transformer from damage due to a current overload (short circuit) condition. For continued protection against risk of fire, replace only with the same fuse type and rating. Ensure power to the controller is disconnected prior to removing or installing fuse.

1. Disconnect the main power source to the controller.
2. Open the controller door.
3. Pull the control module open by grasping it from the right edge (press the module release tab on the outdoor model).
4. Locate the fuse on the PC board (see page 9). Carefully remove the fuse from the retaining clip.
5. Install a new 2.0A (slow-blow) fuse, ensuring that it is properly seated in the retaining clip.
6. Reconnect power to the controller.

Note: *If the 9V battery did not support the control module power requirement, current time and day will need to be reset. Refer to pages 5 and 6 for battery replacement procedure.*

❖ Remote Control Feature

The Rain Dial controller is remote-ready and is fully compatible with both Irritrol Handheld Remote Control models: the close-range residential model KSR-KIT, and the long-range commercial model CMR-KIT. Both remote models offer the same convenient remote control features. Refer to the user guide provided with each remote kit for complete information.

As shown in the illustration below, the KSR-KIT receiver plug assembly simply plugs into the receptacle provided in the back of the Rain Dial control module. The CMR-KIT receiver plug assembly also requires connection to the 24 VAC power terminals.

Note: *The receiver plug assembly of the two remote models look similar, but are not interchangeable.*

Figure 10

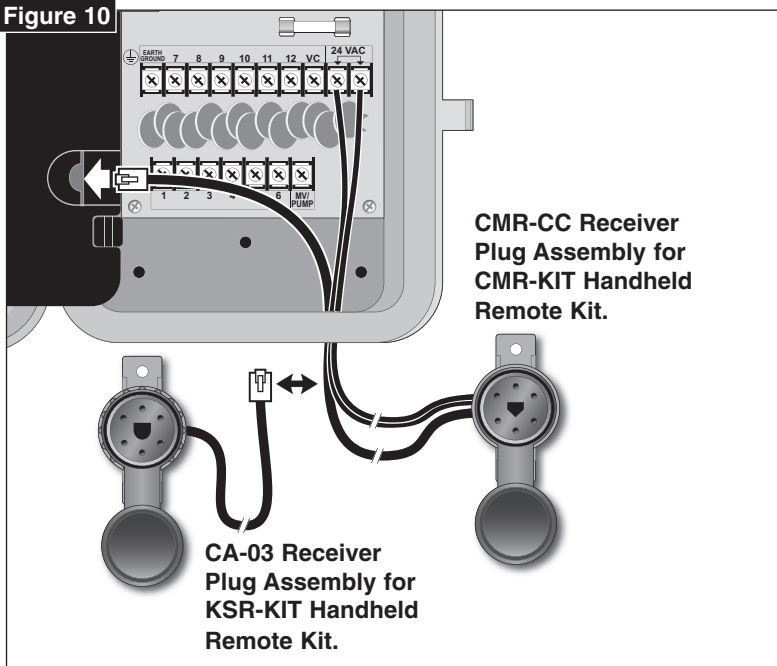

❖ Specifications

Outdoor Models:

- Input: 120 VAC 60 Hz, 30 VA (Domestic), 230 VAC, 50 Hz, 30VA (International) 240 VAC, 50 Hz, 30VA (Australia)

Indoor Models:

- Input: 24 VAC, 60 Hz, 30 VA (domestic) or 24 VAC, 50 Hz, 30 VA (International and Australian)

All Models:

- Station Output: 24 VAC at 0.5A, 1.0A (maximum total)
- Master Valve/Pump Start Relay Output: 24 VAC at 0.375A
- 2.0A Slow-blow Fuse
- Battery Back-up (time, day and date)
- Operating temperature range: 32°F to 140°F (0°C to 60°C)

▲ Caution: The Rain Dial is designed to operate 24 VAC valve solenoids rated at 0.25A (6 VA). Current total load must not exceed 1.0A maximum. A maximum of two solenoids per station terminal may be used, but not to exceed 0.5A per station. No more than three solenoids (plus MV/Pump circuit) should be on at any one time .

To prevent controller damage, do not link the valve common wire of two or more controllers. Use a separate valve common wire for each controller.

❖ FCC Rules

Domestic: This equipment has been tested and found to comply with the limits for a Class B digital device, pursuant to Subpart J of Part 15 of the FCC Rules. These limits are designed to provide reasonable protection against harmful interference in a residential installation. This equipment generates, uses and can radiate radio frequency energy and, if not installed and used in accordance with the instructions, may cause harmful interference to radio communications. However, there is no guarantee that interference will not occur in a particular installation. If this equipment does harmful interference to radio or television reception, which can be determined by turning the equipment off and on, the user is encouraged to try to correct the interference by one or more of the following measures:

1. Reorient or relocate the receiving antenna.
2. Increase the separation between the equipment and receiver.
3. Connect the equipment into an outlet on a circuit different from that to which the receiver is connected.
4. Consult the dealer or an experienced radio/TV technician for help.

The user may find the following booklet prepared by the Federal Communications Commission helpful:

“How To Identify and Resolve Radio-TV Interference Problems.” This booklet is available from the U.S. Government Printing Office, Washington, DC 20402, stock # 004-000-00345-4.

International: This is a CISPR 22 Class B product.

For Product Inquiries:

U.S.A.

P.O. Box 489
Riverside, California 92502
Tel:(909) 785-3623
(800) 634-8873

Australia

Irritrol PTY Ltd.
53 Howards Road
Beverley, SA 5009
Tel: (08) 8300 3633

Europa

Irritrol Europe s.p.a.
Via dell'Artigianato, 1/3-Loc
Prato della Corta
00065 Fiano Romano (Roma),
Italia
Tel: (39) 0765 455201

Irritrol® *Get more done*™